

# Filters and Ring Core Chokes

## FP / L / LP Series

### Accessories



These Filters and chokes are designed to reduce input interference and/or output ripple voltages occurring in applications with switched mode power supplies. Since all our filters contain a Moly Permalloy Powder (MPP) ring core they feature very low DC losses as well as high DC magnetisation and operate perfectly at the input and/or output of switching regulators ensuring effective filtering even at elevated DC current levels. These special characteristics allow the chokes to be operated at DC currents which considerably exceed the rated current, by accepting a corresponding gradual loss of inductance (unlike ferrite core chokes where inductance rapidly decreases above a certain DC magnetising level).

In applications where switching regulators have long supply lines, filters and chokes are used in order to prevent oscillations caused by their negative input impedance. For further information refer also to switching regulator data for "Option L", and to section: *Technical Information: Installation & Application.*

Table 1a: Type survey of FP filter blocks

Filter type	Part number	Matching switching regulator type
FP 38	HZZ 00903	PSR 54 PSA 55 PSA 5A2 PSA 5A5 PSA 123 PSA 153
FP 80	HZZ 00904	PSR 53 PSR 122.5 PSR 152.5 PSR 242 PSR 362 PSA 242.5
FP 144	HZZ 00905	PSA 121.5 PSA 151.5 PSA 241.5 PSA 361 PSA 481

Table 1b: Type survey ring core chokes

Type	Inductivity	$I_{Ln}$	Single coil	Symm. coil	Part number
LP 34-3	34 $\mu$ H	3 A	•		HZZ 00501
L 20-7	20 $\mu$ H	7 A	•		HZZ 00502
LP 20-7	20 $\mu$ H	7 A	•		HZZ 00503
LP 183	2 x 183 $\mu$ H	8 A		•	HZZ 00504

### Table of Contents

Description ..... 1  
 Filter Blocks FP Types ..... 2

Low-Loss Ring Core Chokes L/LP-Series ..... 4  
 Mechanical Dimensions ..... 6

### Filter Blocks FP Types

The filter blocks contain, in addition to a MPP ring core, a capacitor and an attenuation resistor, capable of handling the high ripple currents seen at the input of switching regulators. This forms a complete external filter system optimised to prevent oscillations and to reduce superimposed interference voltages and currents, specially designed for use in PCB applications together with switching regulators in an A01 case size. For selection of filters refer to the type survey.

### Electrical Data Filter Blocks

General Condition:  $T_A = 25^\circ\text{C}$  unless otherwise specified

Table 2: Filter blocks FP

Characteristics		Conditions	FP 38			FP 80			FP144			Unit
			min	typ	max	min	typ	max	min	typ	max	
$I_{Fn}$	Rated current	$L = 0.75 L_o$		4			4			2		ADC
$U_{Fn}$	Rated voltage	$T_{C\ min} \dots T_{C\ max}$	5		40	5		80	15		144	VDC
$R_F$	Ohmic resistance		18	20	22	18	20	22	90	95	100	mΩ
$L_o$	No load inductance	$I_L = 0, T_{C\ min} \dots T_{C\ max}$	30	34	38	30	34	38	88	100	112	μH
$T_A$	Ambient temperature	$I_F = I_{Fn}$	-40		80	-40		80	-40		95	°C
$T_C$	Case temperature		-40		92	-40		92	-40		98	
$T_s$	Storage temperature		-40		100	-40		100	-55		100	

For currents  $I_F > 4\text{ A}$  the following derating takes place:  $T_{A\ max} = 100 - 1.3 \cdot I_F^2 [^\circ\text{C}]$ ,  $T_{C\ max} = 100 - 0.49 \cdot I_F^2 [^\circ\text{C}]$

### Input Interference Reduction

An AC ripple current can be measured at the input of any switching regulator, even if they are equipped with an input filter. Depending on the types of filters used, common and/ or differential mode interferences can be reduced. They will also help to further increase the surge and burst immunity of the power supplies.

The FP filters considerably increase the source impedance of the regulators superimposed interference, to a value which is normally high in comparison to the impedance of the source ( $Z_{Line}$ ). The interference currents are therefore practically independent of their source impedance. The filter will reduce these currents by approximately 25 dB at a frequency of 150 kHz.

The interference voltages at the filter input are due to the remaining interference currents flowing through the source impedance. The resulting interference voltage reduction can be seen in the following figure. For frequencies above the regulator switching frequency the attenuation will increase (up to 2 MHz approx.).

Parallel operation: When several switching regulator inputs are connected in parallel, each regulator should be equipped with a separate input filter. Interconnections should only be made in front of the filter or at its input  $U_{ii}$  (i. e. the central ground point should be before or at the filter and under no circumstances at the regulator input).

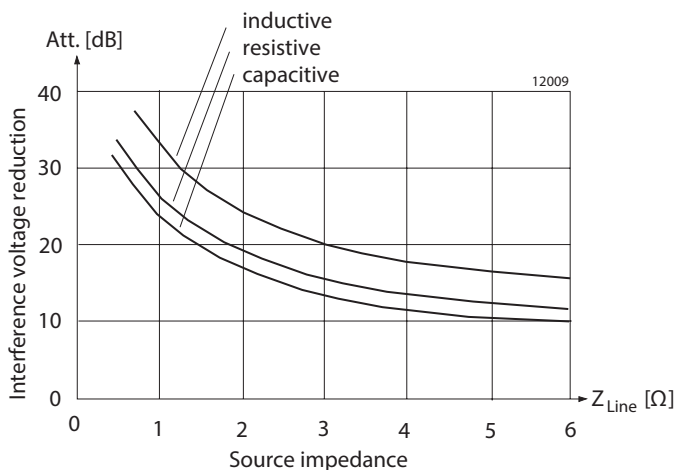

Fig. 1  
Interference voltage reduction with FP filters at  $f = 150\text{ kHz}$

### Reduction of Output Ripple

Even though the switching regulators have an inherently low output ripple, certain sensitive applications need even further reduction. In such cases, the filters designed to reduce disturbances at the input, can also be used for reducing the ripple on the output voltage (even better results with regard to the ripple and dynamic control deviation can be achieved by using the low-loss ring core chokes in combination with an external capacitor, see below).

The output ripple can be reduced by the use of filter blocks by about 24 dB. The formula for the ripple  $u_R$  at the load  $R_L$  is as follows:

$$u_R = 0.063 \cdot u_o$$

(Ripple voltage  $u_o$  is given for specific regulators in the corresponding data section).

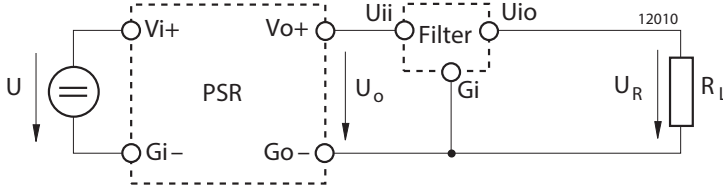

Fig. 2  
Reduction of voltage interference by FP filters

Consider, that the filter not only affects the output ripple but can also influence the voltage across the load  $R_L$  in the event of load changes. The static load regulation increases with the ohmic resistance of the choke i.e. 24 mV/A for the FP 38 and FP 80 filters and 95 mV/A for the FP 144 filter.

### Typical Application

The example in figure *Reduction of voltage interference by FP filters* shows a switching regulator operating from a battery ( $R_i < 0.5 \Omega$ ) with long supply lines (e.g. 2 m). The resulting superimposed interference voltage  $U_{SL}$  may be measured at the regulators input. The connection of a filter in front of the power supply will reduce this interference accordingly:

1. The regulator's source impedance is mainly inductive because of the low battery impedance and the long supply lines. It can be calculated as follows:

$$|Z_{Line}| \cong 2 \pi \cdot f_s \cdot L_{Line} \cdot 2 l$$

$$|Z_{Line}| \cong 2 \pi \cdot (150 \cdot 10^3) \cdot 10^{-6} \cdot 2 \cdot 2 \cong 3.8 \Omega$$

$f_s$ : Switching frequency (150 kHz)

$L_{Line}$ : Supply line inductance (typically  $1 \mu\text{H}/\text{m}$ )

$l$ : Length of single supply line (twice for positive and negative path)

2. This example shows, that with an inductive source impedance of  $3.8 \Omega$ , the insertion of the filter results in an interference voltage reduction of approx. 18 dB (see fig.: *Interference voltage reduction with FP filters at  $f = 150 \text{ kHz}$* ).
3. The original superimposed interference voltage will be reduced by a factor of approx. 8:

$$U_{SF} = U_{SL} \cdot 10^{-18/20} [\text{V}]$$

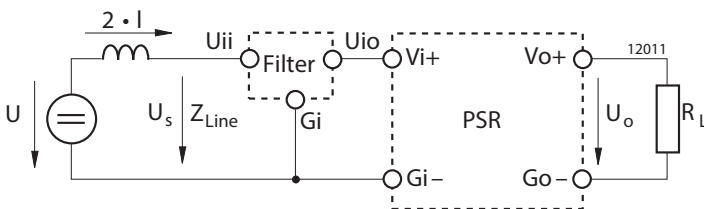

Fig. 3  
Reduction of voltage interference by FP filters

### Low-Loss Ring Core Chokes L / LP-Series

The ring core chokes, in combination with a capacitor, may easily be used for application specific LC filters at the input or output of switched mode power supplies. All chokes are suitable for PCB mounting. They are either moulded into plastic cases or isolated from the PCB by means of an isolation pad.

Series L/LP 20-7 and LP 34-3 are intended for use as differential mode filters and the current compensated choke LP 183 enables attenuation of common mode interference.

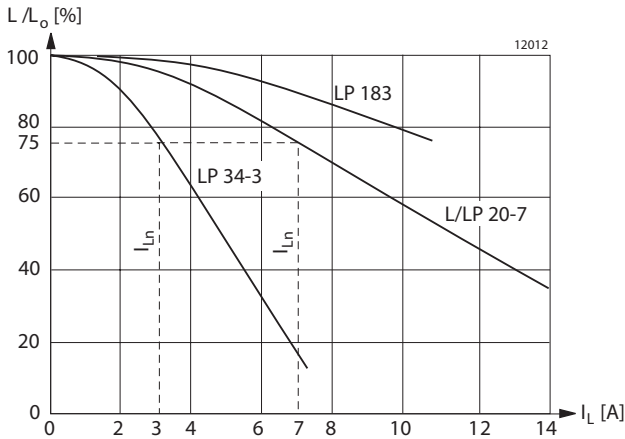

Fig. 4  
Choke inductance versus current

### Electrical Data Ring Core Chokes

General Condition:  $T_A = 25^\circ\text{C}$  unless otherwise specified

Table 3: Ring core chokes

Characteristics		Conditions	L 20-7/LP 20-7			LP 34-3			LP 183			Unit
			min	typ	max	min	typ	max	min	typ	max	
$I_{Ln}$	Rated current <sup>1</sup>	$L = 0.75 L_o$		7			3			8		ADC
$R_L$	Ohmic resistance		5	5.5	18	18	22	22	2x 2.9	2x 4.2	2x 5.5	mΩ
$L_o$	No load inductance	$I_L = 0, T_{C\ min} \dots T_{C\ max}$	18	20	22	30	34	38	2x 95	2x 183	2x 245	μH
$\Delta_{Ti}$	Current specific case temp. increase <sup>1</sup>			0.082			0.68			0.19		K/A <sup>2</sup>
$T_A$	Ambient temperature <sup>1</sup>	$I_L = I_{Ln}$	-40		106	-40		104	-40		98	°C
$T_C$	Case temperature		-40		110	-40		110	-40		110	
$T_S$	Storage temperature		-40		110	-40		110	-40		110	

<sup>1</sup> If the choke is not operating at the rated current  $I_{Ln}$ , the maximum ambient temperature  $T_{A\ max}$  and the maximum direct current  $I_{L\ max}$ , change

according to the following equations:  $I_{L\ max} = \sqrt{\frac{T_{C\ max} - T_{A\ max}}{\Delta_{Ti}}}$        $T_{A\ max} = T_{C\ max} - I_{L\ max}^2 \cdot \Delta_{Ti}$

### Input Interference Reduction

Using L- or LP-series chokes together with an additional external capacitor a similar attenuation can be achieved as with filter blocks. The capacitor between the choke and the converter input is necessary in order to avoid possible oscillations caused by the negative input impedance of the regulator. This phenomenon could cause the input voltage to leave the specified regulator input range. The relatively high ripple current flowing through the capacitor must be considered for the design. Refer also to: *Technical Information: Installation & Application*.

The current compensated choke LP 183 has a high permeability ring core with two identical separate windings. The normal operating current will only see the small stray inductance between the windings. However common mode interference will be blocked by the full inductance of the choke.

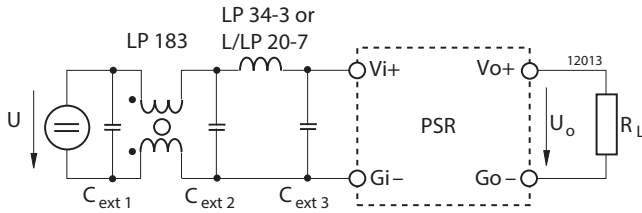

Fig. 5  
L/LP type chokes and capacitors used as input filter

### Typical Application

A voltage drop  $U_{r_{Go}} = r_{Go} \cdot (I_o - I_i)$  is produced across the ground loop resistance  $r_{Go}$ . It is superimposed upon the regulators output voltage  $U_o$  and generates the voltage  $U_R = U_o - U_{r_{Go}}$  across the load resistance  $R_L$ . Without an input inductance  $L_e$  the current  $I_i$  in the input circuit has a relatively high AC component with a basic frequency  $f_s$  (regulator's switching frequency of approx. 150 kHz). This alternating current produces an AC voltage component across  $r_{Go}$  which is superimposed upon  $U_R$ .

To prevent this phenomenon, an inductance  $L_e$  can be inserted into the input circuit. This causes the AC component of the input current to be supplied entirely from the input capacitor  $C_e$ ; thus,  $I_i$  is a pure direct current.  $C_e$  should be wired as close as possible to the regulator's input terminals  $Vi+$  and  $Gi-$ .

$L_e$  and  $C_e$  additionally provide protection against input transients and reduce radio interference voltages.

External connection of  $Gi-$  and  $Go-$  or connection via a common ground is not recommended. The internal voltage drop  $U_{r_G}$  in the regulator would be superimposed on the output voltage.

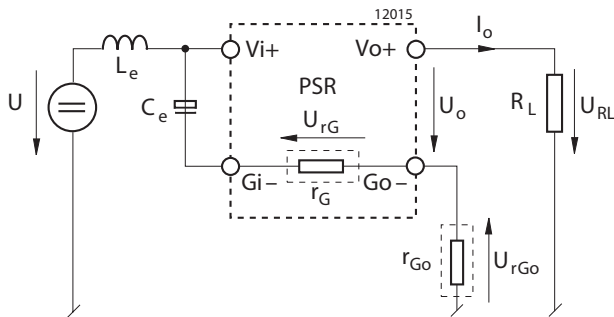

Fig. 6  
Reduction of superimposed interference voltages in grounded power supply systems, caused by ground loops

### Reduction of Output Ripple

Even though the switching regulators have an inherently low output ripple, certain sensitive applications need even further reduction. In such cases, the low-loss ring core chokes designed to reduce disturbances at the input can also be used for reducing the ripple on the output voltage. The chokes in combination with an external capacitor can achieve even better results than the Filter Blocks with regard to the ripple and dynamic regulation.

The formula for the remaining output ripple at the load  $R_L$  is calculated as follows:

$$U_R = u_o \cdot Z_{Cex} / Z_{LD}$$

$u_o$ : Output ripple of the regulator

$Z_{Cex}$ : The impedance of the capacitor at the regulator's switching frequency (150 kHz) corresponds to the equivalent series resistance (ESR) of the capacitor (please refer to the corresponding data sheet).

$$Z_{LD} = 2 \pi \cdot f_s \cdot L_D$$

$f_s$ : 150 kHz (regulator switching frequency)

Through the use of a common mode choke LP 183, the common mode noise at the output can also be further reduced.

Consider that the filter not only affects the output ripple but can also influence the voltage  $U_R$  across the load  $R_L$  in the event of load changes. The static regulation increases with the ohmic resistance of the choke, i.e. 6 mV/A for the choke L/LP 20-7 and 20 mV/A for the LP 34-3.

The dynamic regulation is dependent on the size of the capacitor. Generally, the bigger  $C_{ex}$  the smaller is the dynamic, however, recovery will be slower.

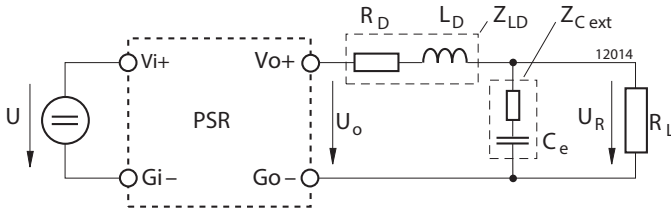

Fig. 7  
Low-loss ring core choke with external capacitor ( $C_{ex}$  approx. 1000  $\mu$ F) used as output filter

### Mechanical Dimensions

Dimensions in mm. Tolerances  $\pm 0.2$  mm unless otherwise specified.

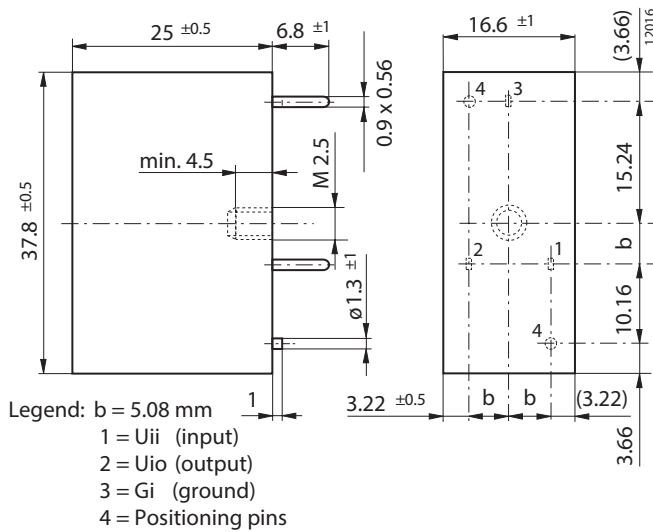

Fig. 8  
Filter blocks FP weight 30 g

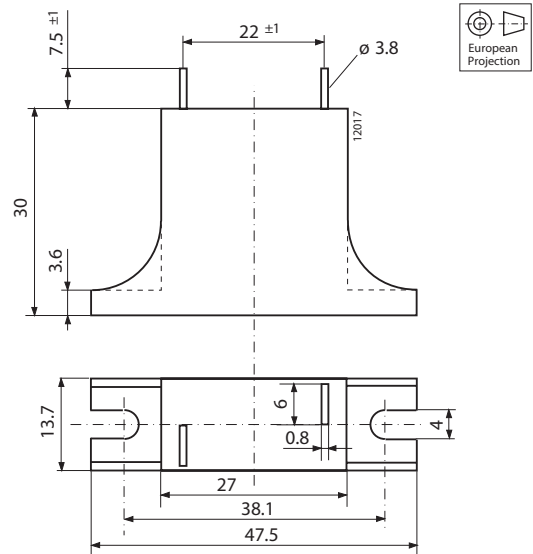

Fig. 9  
Differential mode choke L 20-7, weight 30 g

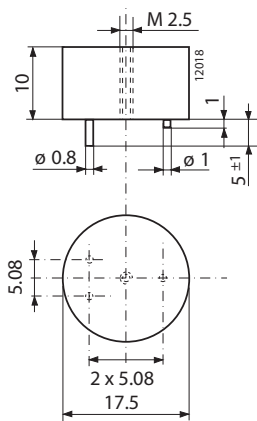

Fig. 10  
Differential mode choke LP 34-3, weight 7 g

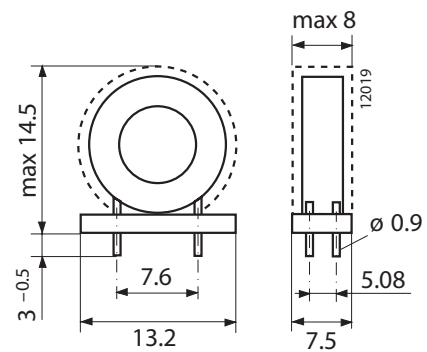

Fig. 11  
Common mode choke LP 183, weight 7 g

**NUCLEAR AND MEDICAL APPLICATIONS** - These products are not designed or intended for use as critical components in life support systems, equipment used in hazardous environments, or nuclear control systems.

**TECHNICAL REVISIONS** - The appearance of products, including safety agency certifications pictured on labels, may change depending on the date manufactured. Specifications are subject to change without notice.